

# PRODUCT DATA



Laser Doppler Vibrometer — Type 8329



The Ometron VH300+ Laser Doppler Vibrometer Type 8329 is a highly accurate and versatile non-contact vibration transducer for applications where it is impossible or undesirable to mount a vibration transducer onto a vibrating object. In those applications the Type 8329 LDV can often replace an accelerometer or microphone. Its ease of use and rugged construction make the Type 8329 LDV suitable in both laboratory and industrial environments. The output signal of the Type 8329 LDV can serve as an input for any existing and future Brüel & Kjær vibration analysing system.

The Type 8329 LDV is an updated version of Ometron's VH300 model. The main difference between VH300 and the VH300+ is that the VH300+ has a higher velocity range.

**8329**

## USES

- Non-contact measurement of vibration velocity
- Vibration measurements on surfaces at extreme temperatures
- Vibration measurements without mass loading on
  - lightweight structures
  - small structures
  - delicate structures
  - soft materials
- Impact measurements
- Relative vibration measurements (e.g., on board ships, aircraft, cars)
- Vibration measurements in any direction

## FEATURES

- Velocity range up to 425 mm/s
- Frequency range from < 0.1 Hz to 25 kHz
- Dynamic range 73.5 dB over full bandwidth
- Measurements from 0.4 m (16 in) up to 25 m (82 ft) possible without surface treatment or retro-reflective tape
- Measurements possible beyond 25 m (82 ft) using retro-reflective tape
- Safe operation (Class II laser)
- Easy to operate with built-in bar graphs
- Portable, compact design with integrated optics and electronics
- Battery or mains operated
- Connects to any Brüel & Kjær sound and vibration analysis system
- Velocity level and focus indications for easy setup

---

## Design

---

### Optics

Laser Doppler Vibrometer Type 8329 is an industrially engineered interferometer manufactured by the Ometron division of Image Automation Ltd. It is based on a Michelson interferometer in which a laser beam is divided into a reference beam and a signal beam. The signal beam is directed onto a vibrating test structure, and the back-reflected light is recombined with the internal reference beam. When the test structure moves, the frequency of the signal beam is shifted, resulting in intensity modulation of the recombined beam due to interference between the reference and signal beams. One complete cycle of the intensity modulation corresponds to a surface movement of  $\lambda/2 = 0.316 \mu\text{m}$ , half the wavelength of the helium neon laser source (where  $\lambda$  is the wavelength of the source,  $0.633 \mu\text{m}$ ). The frequency of this modulation (referred to as the Doppler frequency,  $F_d$ ) is given by  $F_d = 2v/\lambda$ , where  $v$  is the surface velocity.

The recombined light is split into two paths, and a quarter-wave plate used so that the two signals are in quadrature (sine and cosine) allowing the direction of motion to be determined. This allows both the speed and direction of motion to be determined. A balanced detection scheme, with two detectors in each channel, is used for low noise and high sensitivity. Hardware implementation of this measurement principle in the Type 8329 LDV yields a rugged and environmentally tolerant instrument incorporating no perturbing acousto-optic devices (i.e., Bragg cells).

Fig 1 Optical principle of the Type 8329 LDV

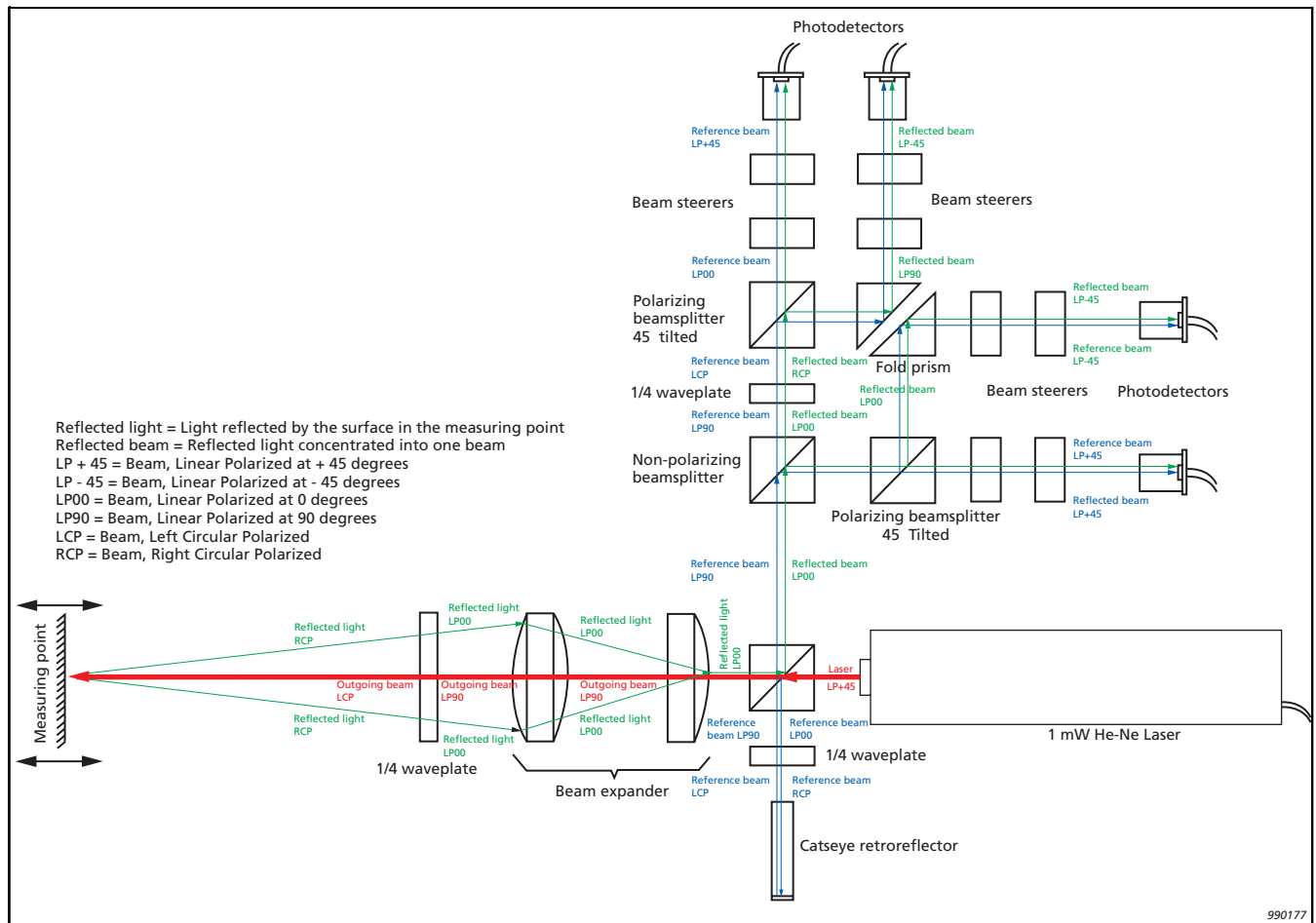

## Electronics

### Preamplifiers

In the preamplifier stage, the current from each pair of photodiode detectors is converted into a voltage by a wideband, low noise amplifier in a screened environment. It is here that the optical signals are turned into electronic signals also known as “Doppler Signals”. These voltages are driven via coaxial cables to the analogue processing board.

### Input Stage

The input filters remove high frequency noise (signal components with a frequency above the maximum expected Doppler frequency for the velocity range of the instrument). The Doppler signals then pass through a dual channel automatic gain control (AGC) circuit which sets the amplitude to an optimum level for the mixer.

### Mixer

A pair of quadrature carrier signals, which are approximations of sine and cosine waves, are produced by a digital circuit. The mixing process involves multiplying each Doppler signal by its corresponding carrier signal and summing the results. The mixer therefore implements the equation:

$$\cos(A - B) = \cos(A) * \cos(B) + \sin(A) * \sin(B)$$

A 6-pole, low-pass Butterworth filter removes any modulation due to unwanted harmonics of the carrier. This produces a frequency-modulated signal that represents the instantaneous velocity of the target, including the information about the direction of motion.

#### *Demodulator*

A comparator and charge pump circuit form a frequency-to-current converter which extracts the velocity information from the FM signal. The current is converted to a voltage, the mean value of which is proportional to the velocity of the target surface.

#### *Output Filter and Calibration*

The demodulator output is low-pass filtered to remove demodulator ripple and set the maximum vibration frequency of 25 kHz. The gain and offset are adjusted to give a calibrated velocity output signal of 1 V per 100 mm/s.

*Fig. 2 Block diagram of Type 8329 LDV electronics*

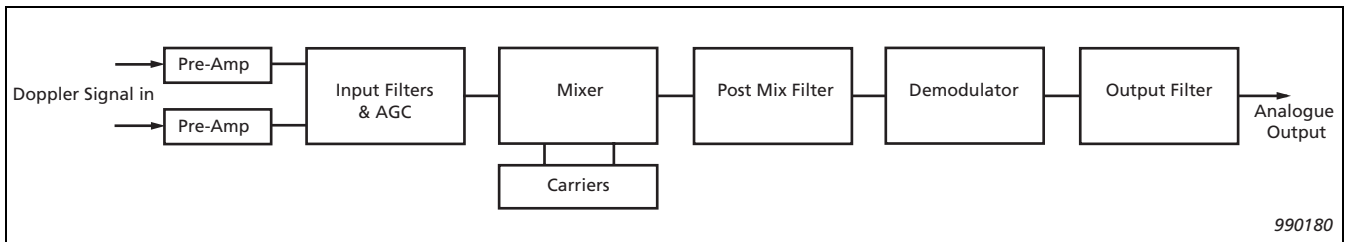

## Basic Battery Kit (Option)



The Type 8329 LDV can be hand held by an operator wearing the belt from the optional Basic Battery Kit ZG 0420. It should be observed, however, that the Type 8329 LDV measures the relative velocity between the sensor unit and the object under investigation. Any movement by the operator will be superimposed on the velocity signal of the object. In addition,

it is difficult for an operator to keep the laser beam fixed on one point on the vibrating surface. If possible, a fixed mounting on, e.g., a tripod is preferred. However, this is usually not a problem above 10 Hz and with higher velocity values.

## Tripod (Option)



The Type 8329 LDV has two mounting points, at the bottom and side of the sensor unit, each having a 1/4" hole with Whitworth thread, a widespread standard used for camera tripods. Type 8329 can be mounted on the Brüel & Kjær Tripod UA 0989.

## Mirror Kit (Option)



Mirror Kit UA 1554 is available for when there is no direct line of sight from the Type 8329 LDV to the target surface. The mirrors are supplied with mounting magnets.

# Measurement Set Up

Fig. 3 System configuration: Type 8329 LDV and Stationary PULSE

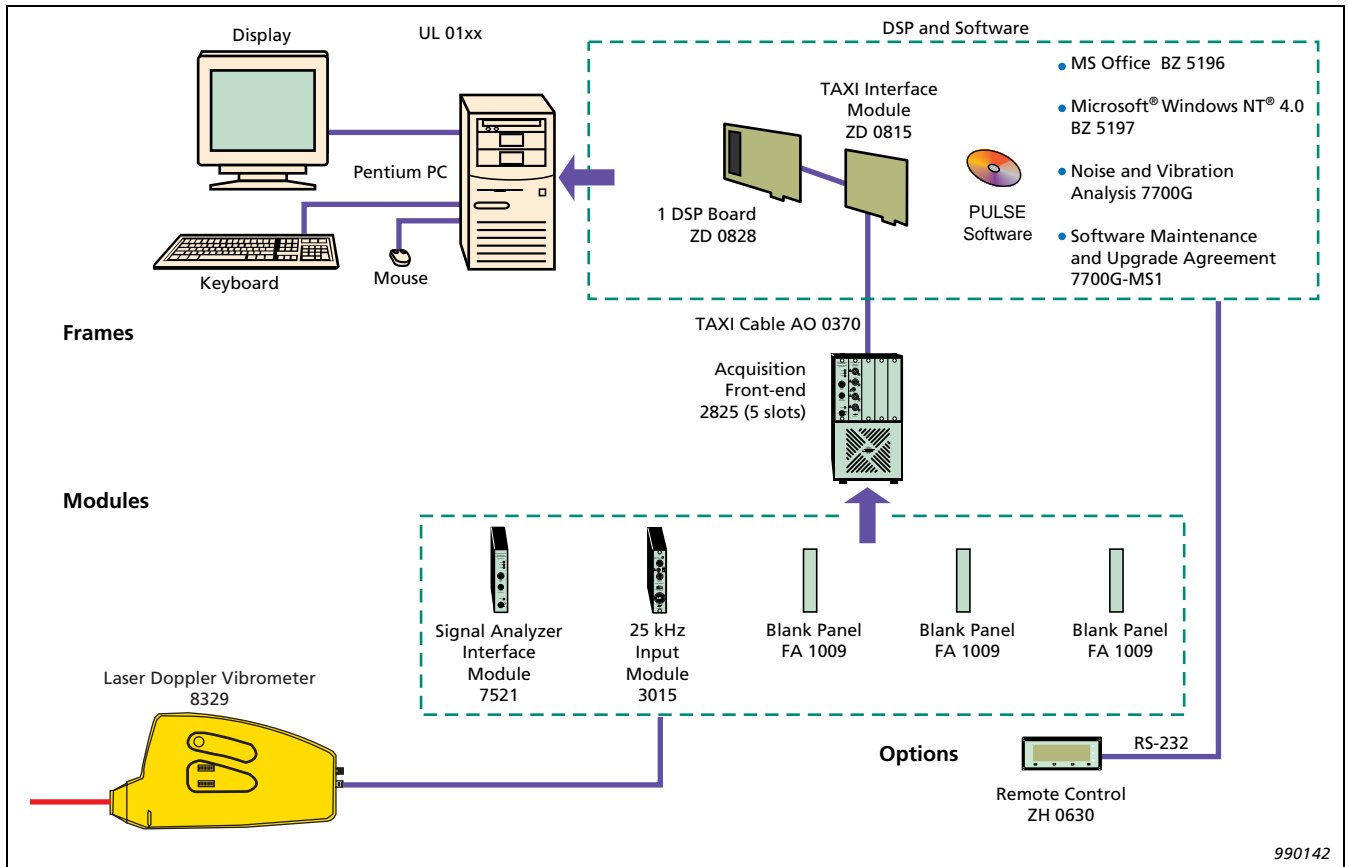
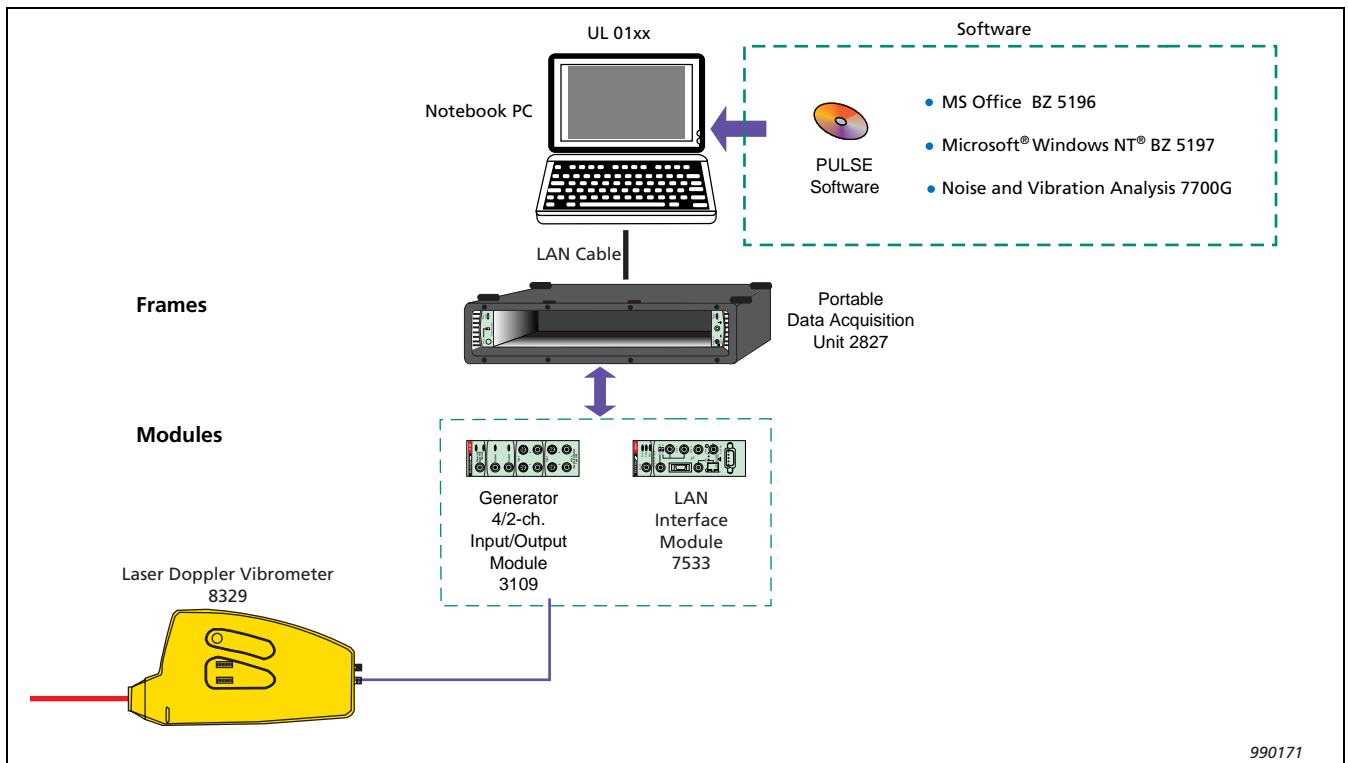

Fig. 4 System configuration: Type 8329 LDV and Portable PULSE



# Calibration

Each product is delivered with a “Certificate of Traceable Calibration” from the manufacturer which certifies that each product has been checked and calibrated against test procedures. The test procedures are listed on the certificate (see Fig. 5).

The factory adjusts the analogue velocity output to a sensitivity of  $10 \text{ mV/mms}^{-1}$  ( $256 \text{ mV/ins}^{-1}$ ). This adjustment is calibrated according to traceable published specifications. For details see “Compliance with Standards”.

Fig. 5 Certificate of traceable calibration for the Type 8329 LDV



**CERTIFICATE OF TRACEABLE CALIBRATION**

Manufacturer : Image Automation Ltd  
Model : VH300+  
Description : Signal point vibrometer  
Serial Number : \_\_\_\_\_  
Calibration Date : \_\_\_\_\_

(Recommended re-calibration interval not more than 24 months)

Image Automation Limited certifies that the above instrument has been checked and calibrated against our test procedures listed below; and that it meets or exceeds all published specifications.

Calibration Test Procedures

Electronics : TS 9017 DP 09141  
Optical Setting : PS 9017 GD 00046  
Overall Test : TS 9017 GD 00043

Issued on behalf of Image Automation by

*G M Bryan*

G M Bryan  
Operations Manager

990774

### Cables

#### *Mains Lead*

The Type 8329 LDV is delivered with a mains cable and plug suitable for use in the country of destination.

#### *BNC Cable*

The Type 8329 LDV is delivered with a BNC-BNC cable for either connection of the analogue velocity output signal or connection of the Doppler output signal to a signal analysis system.

#### *Battery Cable (Option)*

The battery cable is included with Basic Battery Kit ZG 0420 and connects the belt with the sensor unit.

### Signal Output Connectors

#### *D1 and D2*

BNC sockets D1 and D2 are the Doppler signals monitoring the basic analogue interferometer signals. D1 and D2 show the modulation at a frequency directly proportional to the instantaneous velocity of the test surface. For a velocity of 1 mm/s, the modulation frequency is 3.16 kHz.

Taken together, D1 and D2 permit determination of the direction of the measured velocity component parallel to the measuring beam: D1 leads or lags D2 by 90° in phase, depending on whether the test surface is moving towards or away from the optical unit.

#### *Analogue Velocity Signal*

A test surface moving towards the Type 8329 LDV generates a positive analogue velocity signal. A test surface moving away from the Type 8329 LDV generates a negative analogue velocity signal. The maximum output voltage is  $\pm 4.25$  V. This sensitivity applies when the Type 8329 LDV is driving a high impedance instrument. The output impedance is 330  $\Omega$  to protect against short circuits. The output sensitivity is 10 mV/mms<sup>-1</sup> (256 mV/ins<sup>-1</sup>).

#### *Trigger Signal*

The trigger output is TTL compatible. When the button on the unit is depressed, the output of the BNC socket changes from high to low. If the button is kept depressed, the output will return to high after 0.25 s.

### Power Supply

The Type 8329 LDV requires a 12 V DC supply from either the Type 8329 LDV power supply unit or Basic Battery Kit ZG 0420. The Type 8329 LDV power supply unit is “universal”, that is, it can be connected to a reliably grounded 230 V AC, single phase 50 Hz supply, or 110 V AC, single phase 60 Hz supply, without the need to change any switches.



---

## Applications

---

### *Environmental Applications*

- Analysing traffic sound absorption by plants
- Quality testing of sound-deadening materials

### *Nuclear Applications*

- Vibration analysis in a contaminated environment measured at long distance

### *Telecommunication Applications*

- Analysis of vibration, caused by wind load, of parabolic antennas on towers

### *Industrial Applications*

- Vibration analysis of car body panels, components and braking systems
- Vibration analysis of household appliances
- Loudspeaker testing
- Quality control of
  - machined metal castings
  - television tubes
  - hard disk or CD-ROM drives
- Lateral and axial vibration measurements on rotating components (e.g., on rotating machinery)
- Hot exhaust systems

### *Research Applications*

- Vibration analysis of models under investigation within a wind tunnel
- General non-contact vibration studies

### *Calibration Applications*

- Transducer calibration

## Type 8329 LDV Nomogram

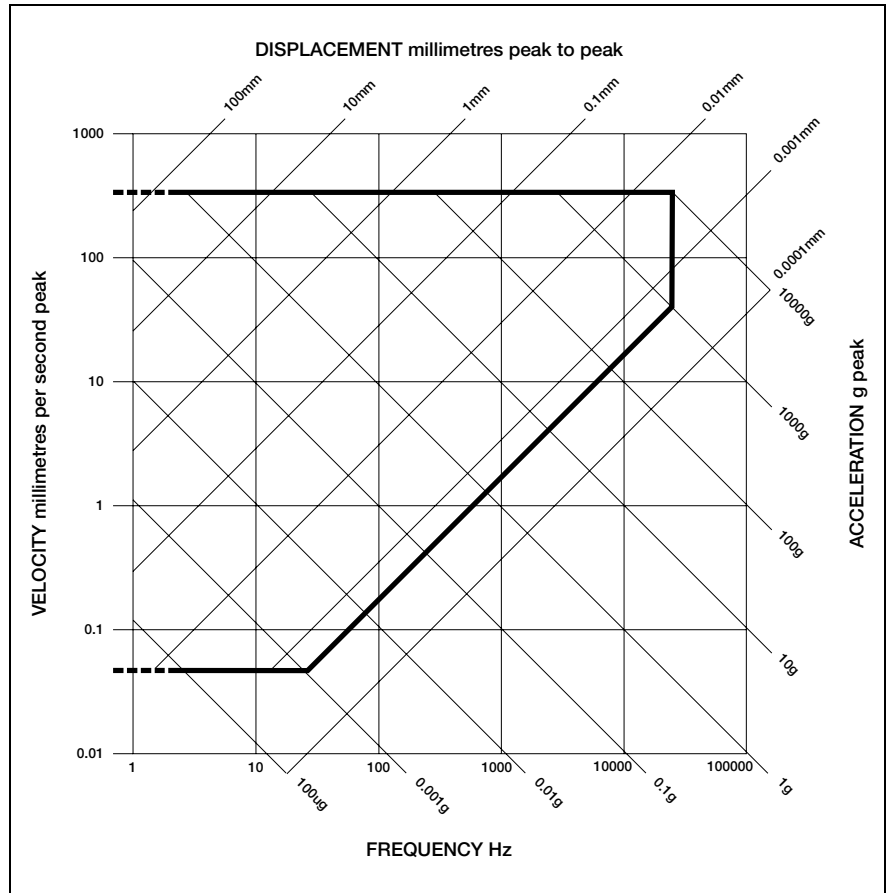

The nomogram in Fig. 6 describes the ranges of acceleration, velocity, displacement and frequency for a quick indication of whether Type 8329 is suitable for the application.

Fig. 6 Nomogram of working ranges for the Type 8329 LDV



For applications outside the area defined by the thick lines, please contact your local Brüel & Kjær representative for alternative solutions.

# Compliance with Standards

 	CE-mark indicates compliance with: EMC Directive and Low Voltage Directive. C-Tick mark indicates compliance with the EMC requirements of Australia and New Zealand
<b>Safety</b>	Electrical Safety: IEC 950. Laser Safety: 21 CFR 1040.10 and 21 CFR 1040.11 (similar to EN 60825-1)
<b>EMC Emission</b>	EN 50081-1: Generic emission standard. Part 1: Residential, commercial and light industry. CISPR 22: Radio disturbance characteristics of information technology equipment. Class B Limits. FCC Rules, Part 15: Complies with the limits for a Class B digital device.
<b>EMC Immunity</b>	EN 50082-1: Generic immunity standard. Part 1: Residential, commercial and light industry.
<b>Temperature</b>	IEC 68-2-1 & IEC 68-2-2: Environmental Testing. Cold and Dry Heat. Operating Temperature: 5 to 35°C (41 to 95°F)
<b>Humidity</b>	IEC 68-2-3: Damp Heat: Operating: up to 80% RH (non-condensing)
<b>Mechanical</b>	IEC 60068-2-6: Test Fc Vibration (sinusoidal), operating: 2 g peak, 10-150 Hz, 1 octave/minute, 10 sweep cycles on each axis BS2011

## Specifications – Laser Doppler Vibrometer Type 8329

### Dynamic

**Velocity Range:** 65  $\mu\text{m/s}$  to 425 mm/s (16.7 in/s) peak  
**Noise Floor:**  $<0.4 \mu\text{ms}^{-1}/\text{Hz}$  @ the midband of 12.5 kHz  
**Frequency Range:**  $<0.1$  Hz to 25 kHz  
**Working Distance:** From 0.4 m (16 in) up to 25 m (82 ft) without surface treatment. Above 25 m (82 ft) on retro-reflective surfaces  
**Spatial Resolution:** Approx. dia. 1 mm (0.04 in) at 10 m (33 ft) working distance  
**Accuracy of output signal:** Better than 1% at analogue output  
**Velocity Output Sensitivity:** 10 mV/mms<sup>-1</sup> (256 mV/in<sup>-1</sup>)  
**Polarity:** Positive analogue velocity signal when the test surface is moving towards Type 8329 and negative analogue velocity signal when the test surface is moving away

### Physical

**Displays:** LED bars for velocity and focus  
**Controls:** Focus ring, trigger button, lens shutter

**Signal Output Connectors:** Analogue velocity ( $\pm 4.25$  V), Laser Doppler ( $\times 2$ ), Trigger  
**Laser:** He-Ne continuous wave laser,  $<1$  mW output power, 632.8 nm (red light)  
**Laser Safety Class:** Class II  
**Dimensions:** 75  $\times$  175  $\times$  350 mm (3  $\times$  6.9  $\times$  13.8 in)  
**Weight:** 3.7 kg (8.2 lb.)

### Electrical

110 – 230 V, 50 – 60 Hz, mains supply using the Type 8329 LDV power supply  
 12 V DC, 1.2 A, 15 VA supply

### Environmental

**Operating Temperature:** +5 to +35°C (+41 to +95°F)  
**Operating Relative Humidity:** Up to 80% (non-condensing)  
**Operating Altitude:** Up to 2200 m (7200 ft)

# Ordering Information

Type 8329 Laser Doppler Vibrometer  
Includes the following items:

Main sensor unit  
Lens cap  
Power supply 110 – 230 V, 50 – 60 Hz  
Mains lead  
BNC-BNC cable  
Shipping case  
Pressure release valve  
User manual  
Allen key  
Laser Safety Inspection and Test Report  
EC Declaration of Conformity  
Certificate of Traceable Calibration

---

## Optional Accessories

---

ZG 0420 Basic Battery Kit  
• Battery Belt with NiCd battery giving up to 4 hours continuous operation  
• Battery Cable for Type 8329 LDV  
UA 1554 Mirror Kit  
• High reflectivity 75 × 75 mm mirrors with metallic bases  
• Extension rods  
• Magnets  
• Knuckle joint  
• Plastic carrying case, that fits in the shipping case of the Type 8329 LDV  
UA 0989 Tripod  
DU 0164 Retro-reflective Tape (Sheet)  
QA 0137 Retro-reflective Tape (Roll)

---

# Complete PULSE™ Based Vibration Analysing System

Type 8329 Laser Doppler Vibrometer  
Type 2825 Acquisition Front-end  
Type 3015 25 kHz Input Module  
Type 7521 Signal Analyzer Interface Module  
3 × FA 1009 Blank Panel  
AO 0370 Taxi Cable  
ZD 0815 Taxi Interface Module  
ZD 0828 120 MFLOPs DSP Board  
UL 01xx\* Complete PC  
BZ 5197 Microsoft® Windows NT®  
BZ 5196 Microsoft Office  
Type 7700 G Noise and Vibration Analysis Software  
3560-SI4 Pre-configuration and Testing of PC

---

## Optional Accessories

---

ZH 0630 RS-232 Remote Control  
7700 G-MS1 Software Upgrade Agreement  
ZG 0420 Basic Battery Kit  
UA 1554 Mirror Kit  
UA 0989 Tripod  
DU 0164 Retro-reflective Tape (Sheet)  
QA 0137 Retro-reflective Tape (Roll)

\*The PC configuration evolves continuously. Please check with a local Brüel & Kjær Sales Engineer

---

# Complete Portable PULSE Based Vibration Analysing System

Type 8329 Laser Doppler Vibrometer  
Type 3560 C PULSE Multi-analyzer System

Included in 3560 C are the following products

Type 2827 Portable Data Acquisition Unit  
Type 7533 LAN Interface Module  
Type 3109 Generator, 4/2-ch. Input/Output Module  
UL 01xx† Pentium® II or III Notebook PC  
Type 7700 G Noise and Vibration Analysis Software  
BZ 5197 Microsoft Windows NT  
BZ 5196 Microsoft Office

---

## Optional Accessories

---

ZG 0405 Battery Charger for Type 2827  
2 × QB 0048 Battery, NIMH DR35  
UA 1556 Notebook Mounting Kit  
KE 1000 Carrying Case for Portable PULSE and Notebook PC  
ZG 0420 Basic Battery Kit  
UA 1554 Mirror Kit  
UA 0989 Tripod  
DU 0164 Retro-reflective Tape (Sheet)  
QA 0137 Retro-reflective Tape (Roll)

†The PC configuration evolves continuously. Please check with a local Brüel & Kjær Sales Engineer

---

Brüel & Kjær reserves the right to change specifications and accessories without notice